

A15R

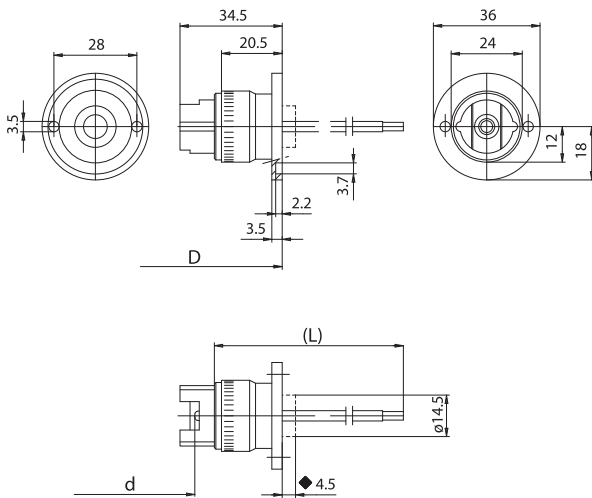

◆ Maximum jut of the porcelain body during lamp insertion

A15R: lampholder as A15 with envelope in nickel-plated brass with back round part, diameter 36 mm, with groove and fixing holes diameter 3,2 mm with center distance 28 mm.

A15RM: cURus version with device to block the body connected to the line (see A15M).

- D: fixing distance of the lampholders pair on rigid structures:
 - 169,0 mm for lamps with RX7s cap, with "Z nom." lamp 114,2 mm (70W)
 - 186,8 mm for lamps with RX7s cap, with "Z nom." lamp 132,0 mm (150W)
- d: distance between the contacts = D - 58,5 mm
- Weight of the lampholders pair in standard execution: 115 g.
- Instructions to fix the lampholder on structures.

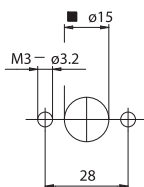

■ Insertion hole of the porcelain body during lamp insertion

- Fixing of the lampholders pair by M3 screws, with maximum head diameter 6 mm, to be inserted in the fixing holes with center distance 28 mm.

A15C

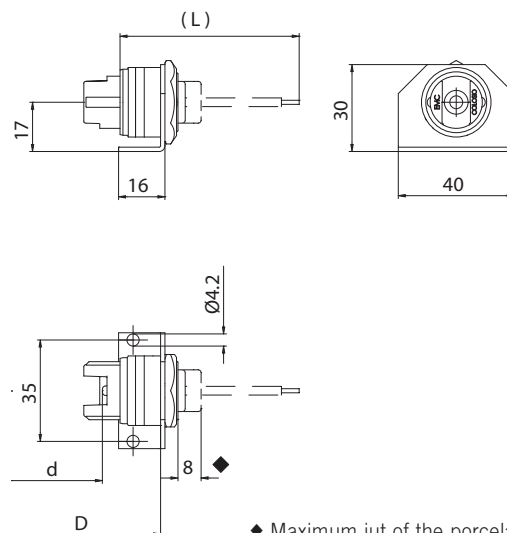
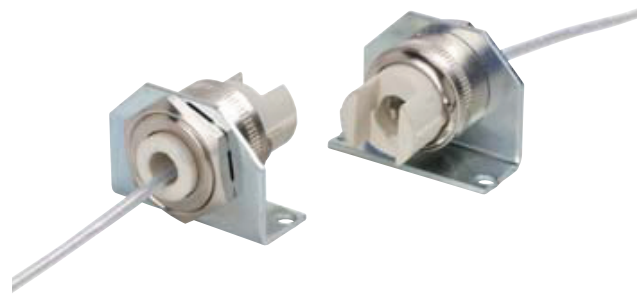

◆ Maximum jut of the porcelain body during lamp insertion

A15C: lampholder as A15 with zinc-plated fixing bracket, with holes diameter 4,1 mm with center distance 35 mm.

A15CM: cURus version with device to block the body connected to the line (see A15M).

- D: fixing distance of the lampholders pair on rigid structures:
 - 131,0 mm for lamps with RX7s cap, with "Z nom." lamp 114,2 mm (70W)
 - 149,0 mm for lamps with RX7s cap, with "Z nom." lamp 132,0 mm (150W)
- d: distance between the contacts = D - 20,5 mm
- Weight of the lampholders pair in standard execution: 120 g.
- Instructions to fix the lampholder on structures.

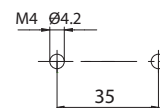

- Fixing of the lampholders pair by M4 screws, to be inserted in the fixing holes with center distance 35 mm.