

A45A

2001



Clamps support for lamps with cap:

Rated voltage:
 Rated current:
 Working temperature:
 Type of clamps to connect the cables:
 Clamps connecting capacity:
 Connected cables working temperature:
 Overvoltage category:

K12s

500 V
 12 A
 T 280°C

SCREW CLAMP

1.50 ÷ 4.00 mm²

T 180° ÷ 250° C
 III

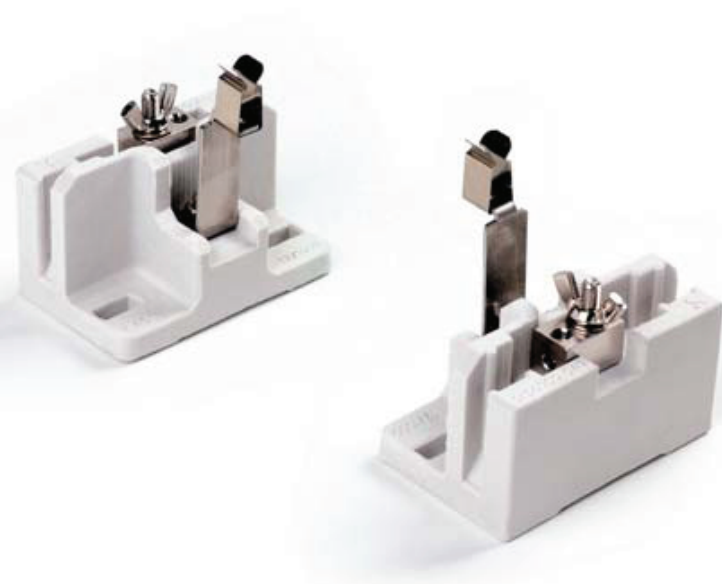

Connecting cables to the clamps:

Insulation	T in °C	Conduct.	Available sections and tensions			
			Pulse kV	1,50 mm ²	2,50 mm ²	4,00 mm ²
Oversize silicone <i>Single insulation</i>	180	CuSn	10kV	•	•	
Oversize silicone <i>Single insulation</i>	180	CuSn	5kV	•	•	
Silicone+Silicone <i>Single insulation</i>	180	CuSn	5kV	•	•	
Oversize PTFE <i>Single insulation</i>	250	CuNi	5kV	•	•	
Oversize PTFE +PFA <i>Double insulation</i>	250	CuNi	5kV	•	•	

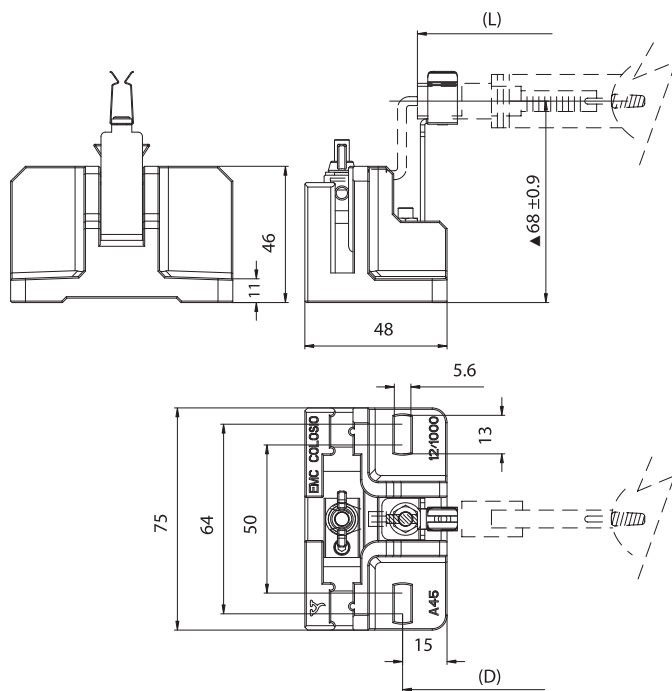

▲ Focus point of the lamp



CERAMIC SUPPORT FOR DISCHARGE LAMPS

Attention: this clamp support has uncovered parts under tension. During the project verify that surface and air distance prescribed by lighting fixtures construction standards, will be respected. Verify the protection against accidental contacts.

We can supply this series of items also with the shape of the bracket made as per customer request. Feasibility to be discussed with our technical dept.

- Porcelain body.
Cable clamps in nickel-plated brass.
Tighten of the power cable by M5 grub-screw.
Clamping of the fork-terminal by wing-nut M5 and conical washer.
Support bracket in stainless steel.
Safety retaining lamp spring in stainless steel.
- Weight of the support pair: 400 g.
- D: fixing distance of the support pair on rigid structures:
 - 201,0 mm for lamps L = 187 mm (1000W-2000W)
 - 289,0 mm for lamps L = 275 mm (2000W).
- Instructions to fix the support pair on structures.

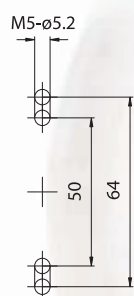

- Fixing of the support pair by M5 screws, to be inserted in the fixing holes, center distance 50±64 mm.

