

P40

CE

Lampholder:

Rated voltage:
Rated current:
Working temperature:
Type of clamps for
cables connection:
Clamps connecting capacity:
Overvoltage category:
Protection degree (IP):
In conformity to the standards:
In conformity to the requirements
of the directive:

BY22d

250 V
4 A
T 250°C

SCREW CLAMPS
0,50 ÷ 1,00 mm²
III
IP20
CEI 34-44 I Ed.

2014/35/EU

Approval marks:

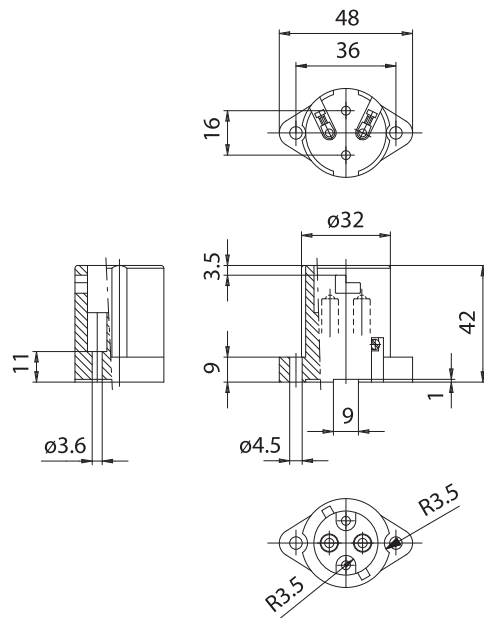
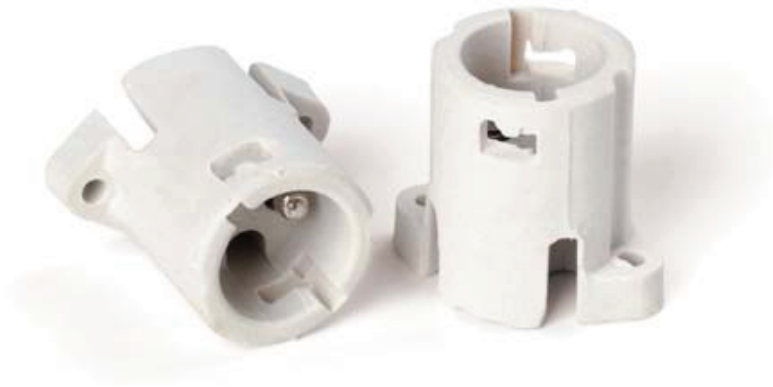

- The accessories, which may be supplied separately, are indicated in “section 4”.



BAYONET CAP LAMPHOLDERS

Note: to tighten the clamps screws, use a screwdriver with a slot max. diameter 3,5 mm.

- Porcelain body.
Contact in nickel-plated brass.
Contacts pressure springs in normalized stainless steel.
Nickel-plated brass clamps with slot screws not completely tightened.
- Weight: 55 g.

- Instructions to fix the lampholder on structures.

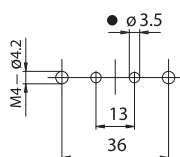
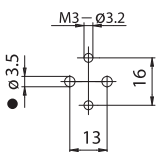

- Suggested minimum dimension for cables passage (if necessary)

- Fixing of the lampholder using the holes diameter 3,6 mm with center distance 16 mm, or the holes diameter 4,5 mm with center distance 36 mm.

